

1. SPECIFICATION

AR-1332DA-21W

ITEMS.		SPECIFICATIONS
01	Type	Dynamic 13mm receiver unit
02	Sensitivity (S.P.L)	115dB \pm 3 dB at 1kHz 180mV with IEC 318 coupler
03	Impedance.	32 Ohm \pm 15% at 1KHz
04	Magnet Field Intensity.	Axial – dB , Radial –dB at 1KHz
05	Nominal Input Power	10mW
06	Max. Input Power.	Must be normal at a white noise , 26mW(900mV) for 1 minute.
07	Total Harmonics Distortion	Max 5 % at 1K Hz.

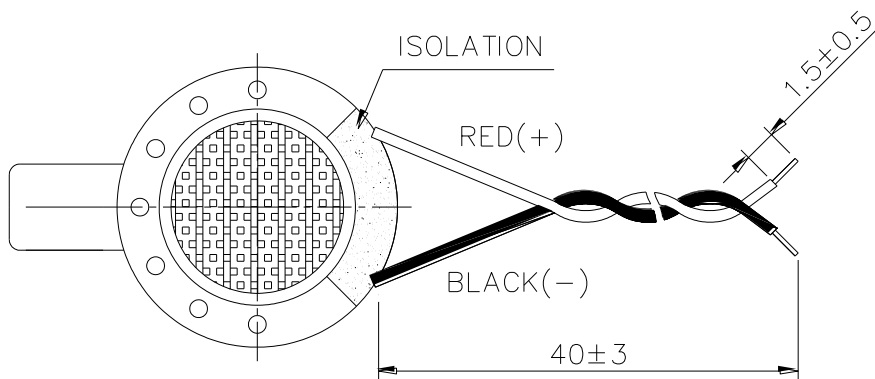

WIRE : UL1571 AWG32

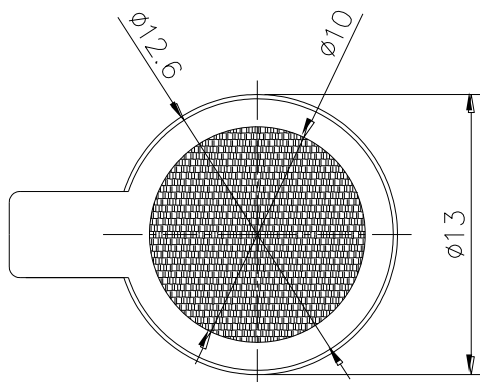
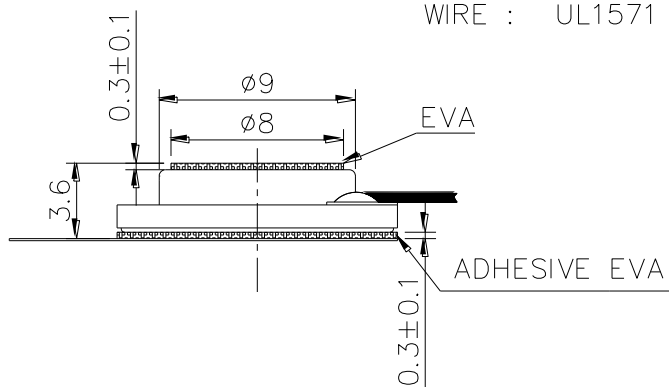

MATERIAL

HOUSING : METAL

DIAPHRAGM : PEI

TITLE: DYNAMIC RECEIVER		DRAWN: JOHN	01/27/2005	SCALE: 3:1	SHEET: 1 of 1
PART NO. AR-1332DA-21W		DESIGNED: R & D OF AAT	UNITS: mm		
DWG NO. DTR-1085		CHECKED:	TOLERANCE ± 0.2		
		APPROVAL:	UNLESS OTHERWISE SPECIFIED:		
REV 1		MATERIAL: *****	ONE PLACE DECIMAL ± ***		
			TWO PLACE DECIMAL ± ***		
			THREE PLACE DECIMAL ± ***		

KOYO ELECTRONICS COMPANY LIMITED

For more information, please contact AATC.